

MANUAL PUNCH PRESS

INSTRUCTION MANUAL

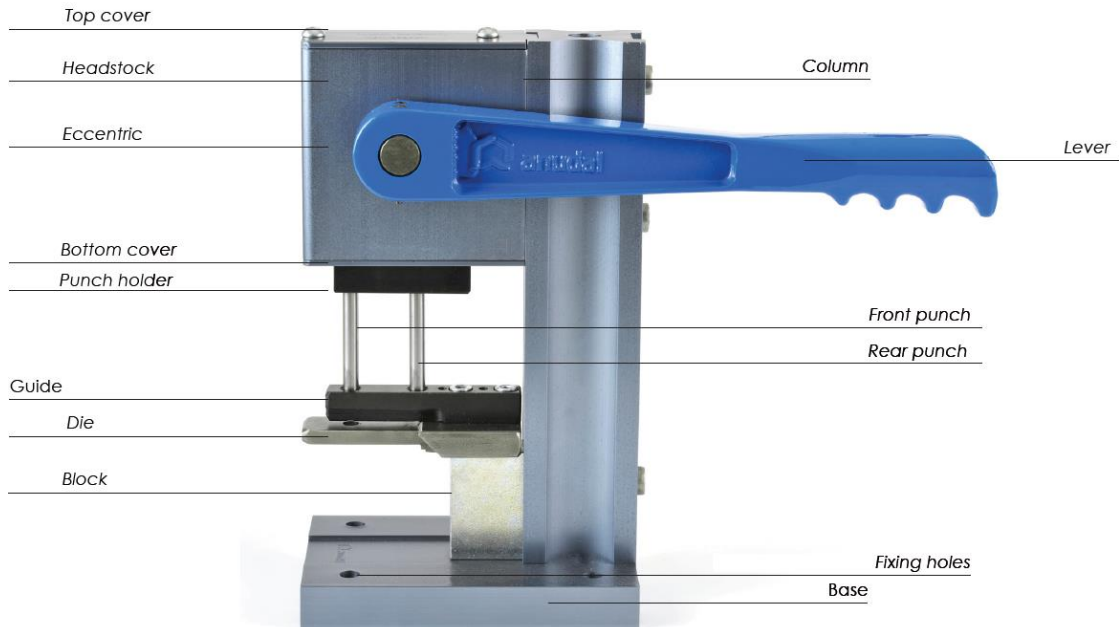



Applications

Punching machine designed for die-cutting aluminum profiles with a maximum thickness of 2mm.

Maintenance and Service

Periodically grease the punches to avoid seizing them.

In case this instruction manual does not solve your problem, please contact us requesting the technical assistance service.

Start-up

1. Fix the punching machine in a horizontal and stable place and at the appropriate height to avoid that the machine falls during usage. To fix it, use the holes incorporated in the base. Figure 2
2. In case it's needed, add the according supplement to the die, fixing it with the screw supplied.
3. Insert the aluminum profile on the side that needs to be cut, with the profile's side to be punched adjusted to the die. Figure 3
4. Move the lever to operate the punches. It is advisable to have the punching machine firmly fixed to a workbench. Figure 4
5. Finally, remove the profile and repeat the operation from point 4 as many times as necessary.

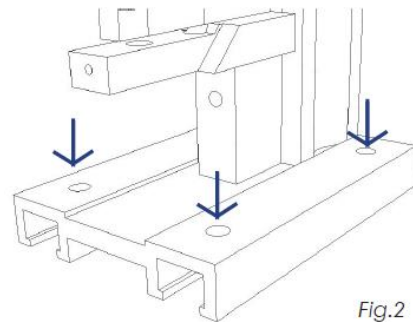

Fig.2

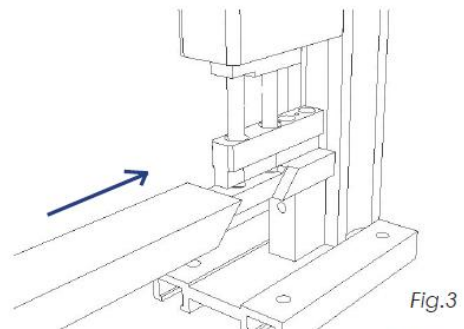

Fig.3

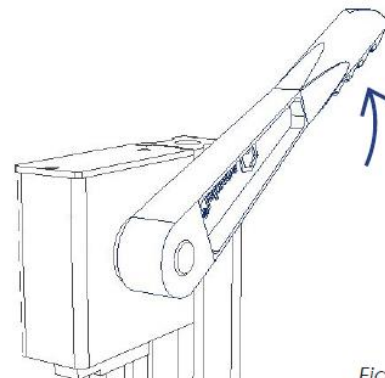

Fig.4